

# Development of an Improved Groundnut Oil Expelling Machine for Medium Scale Industries

**Mogaji P. B.<sup>1</sup>, Ayodeji O. Z.<sup>2</sup>, Akintunde O.<sup>2</sup>**

<sup>1</sup>Department of Industrial and Production Engineering, Federal University of Technology, PMB 704, Akure, Ondo State, Nigeria.

<sup>2</sup>Department of Mechanical Engineering, Federal University of Technology, PMB 704, Akure, Ondo State, Nigeria.

E-mails: pbmogaji@futa.edu.ng<sup>1\*</sup>, Phone: +2348033560260

## **Abstract**

In the present study, an improved groundnut oil expelling machine was developed to address some of the problems common with the existing expellers including bulky design, large space usage, low product quality and a high degree of impurities. The method used involved selecting appropriate materials, and utilization of theories of failure that enable the determination of allowable shear stress on the bearing supports. Compared to the existing expellers, the designed expeller exhibited a better expelling efficiency which based on the extraction of the quality oil from 25 kg of groundnut per hour. With an improved efficiency of 95.2 % and production cost of about \$445, an expelling machine with capacity of 5 horsepower (hp) was made effective for the expelling of quality oil. The developed expeller with a better performance at a reduced time, affordable price, and excellent expelling efficiency will find applications in most small and medium scale industries.

**Keywords:** Expeller; groundnut oil; efficiency; medium scale; horsepower.

## 1. Introduction

The increase in the population of developing countries is by far greater than increase in food production. The calorie intake of most populace depends on cheap and easily available starch-based food, as they cannot afford the expensive animal-based meal. Therefore, there is need for a cheap source of nutrients (groundnut) to augment the shortage of protein and oil in the diet of large section of the population for proper growth and development. Hence, to meet the requirement of oil intake as recommended by food and agriculture organization (FAO), as well as meeting the demand of indigenous Agro-allied industries, extraction of oil from oil seeds such as groundnut becomes necessary [1-3].

The demand for groundnut oil as major raw material in production of paints, soaps, margarine and cosmetics in most industries requires is on the high side. This therefore calls for an effective means of expelling oil from groundnut seed without much time and energy consumed, and at the same time maximizing the income from the sale of oil and by-product. Groundnuts have been consumed as a food since the origin of humanity. With increase in population and use of groundnut oil, the market demand for groundnut oil also increases. Groundnut oil is one of the first generation of vegetable oil to be produced and processed at commercial scale in Nigeria. The production of this important dietary component is still at the declining trend despite the effort of the different institutes to conduct research and give appropriate advice to government in formulation of the policy that will guide the production, propagation and processing of the groundnut.

In recent years, farmers in Nigeria have been faced with difficulties in substantial production of groundnut oil, one which is expelling of oil from groundnut. Most farmers are still operating at a subsistence level where oil is extracted from groundnut seeds through traditional

means which is mostly depended on human energy. It is time wasting and energy consuming with about 20 – 30 % of the oil extracted [4].

Over the years, the development of groundnut oil expelling machine and the effects of the operating parameters have been a subject of investigation [5-8]. Gitau et al. [5] optimized the performance of two manually operated groundnut decorticator. The performance tests showed that the requirements of the farmers including low kernel breakages and high shelling efficiencies could be achieved by the modified decorticator while the influence of moisture content, duration and temperature of roasting on oil expression from crop using an oil expeller was investigated by Akinoso et al. [6]. In another study, Oghome [7] determined the optimal values of process variables (alcohol-to-oil molar ratio, catalyst concentration, reaction temperature and time) that would result in the maximum yield of biodiesel. In the optimization of groundnut oil biodiesel production and characterization carried out by Bello and Fatimehin [8], the transesterification process was optimized by varying the molar ratio between 1:1 and 4:1, and catalyst between 0.2 and 3.0 g/litre. The highest biodiesel yield was obtained at 2.4 g/litres, with a molar ratio of 4:1 and reaction temperature of 60°C. In the fabrication process, the major design considerations were considered as emphasized by other researchers [9-19].

Findings were gathered from the existing groundnut oil processing plant about the shortcomings, deficiencies and problems during the operations. It was found that there is a lot of wastages from leakage and failure from the heaters and the extracting machines. The existing expelling machines are normally large and heavy which requires a high-power input to operate them (about 15 Hp) and in a low quality of the oil, slip as a result of using belt in transmitting motion, and low output. Also, most of the machine are limited to small scale production [1]. The problems associated with the existing expelling machines had resulted to low production and low

income, and generally affect the efficiency of the expeller. Some of the problems mostly identified with the existing expellers are [2]: (1) bulky design, occupying large space, (2) low product quality and a high degree of impurities, (3) high traces of oil in the by-product, and (4) slip as result of using belt in transmitting motion (i.e. less efficient power transmission design). Hence, there is need to develop an improved expelling machine with higher efficiency and quality oil production [3]. This will reduce the above disadvantages in a best possible way and enhance productivity.

In the present study, an improved expelling machine which can extract oil from groundnut seeds was developed to increase the rate of groundnut oil production in the market and lessen the pains most farmers faced during the extraction process. The major design factors are also considered during the fabrication process.

## **2. Materials and Methods**

### **2.1 Material Selection**

The availability and properties of materials are very important as far as the design process is concerned. Some of the factors considered in the course of this work include availability, weight, strength, appearance, and cost of production. Materials used are mild steel for spacers, flange, angle bar and bolts and nuts; galvanized sheet iron for hopper, expelling chamber, barrel, sieve, and mild steel for coupling and die. The size of the machine is 1614 mm x 254 mm x 632 mm (l x b x h). The main power source for this expelling machine is a 5 – hp electric motor. This supplies the power required and the necessary speed required to operate the groundnut oil expelling machine. The components of the machine are as follows: shaft, flange bearing, coupling, hopper, worm, barrel, bed, expelling chamber, die, lock nut and electric motor.

## 2.2 Design Considerations

The groundnut oil expeller was developed based on the following considerations [20],

- (i) Design capacity of 25 kg of ground nut per hour;
- (ii) Acceleration due to gravity (g) is 9.8 m/s<sup>2</sup>;
- (iii) Ground oil accounts for 38 % of the groundnut by weight;
- (iv) Design speed is 72 rpm;
- (v) Expeller chamber internal diameter,  $d_i$  is 89 mm;
- (vi) Rated speed of electric motor ( $N_m$ ) is 1440 rpm;
- (vii) Density of groundnut ( $\rho_{gn}$ ) is 350 kg/m<sup>3</sup>
- (viii) Worm pitch ( $P_w$ ) is 46 mm
- (ix) Electric motor efficiency is 90 %
- (x) Maximum permissible working stress is 112 MPa
- (xi) Factor of safety (fs) of shaft with keyway is 4, and
- (xii) Shear stress is 56 MPa

### 2.2.1 Determination of Worm Mean Diameter

The worm mean diameter ( $d_m$ ) and worm mean radius ( $r_{mw}$ ) were obtained to be 57 mm and 28.5 mm, respectively using eqn. 1 and 2. However, the worm strip width (W) was obtained with eqn. 3 with the worm crest diameter ( $D_c$ ) of 80 mm.

$$D_m = D_c - \frac{P_w}{2} \quad (1)$$

$$r_{mw} = \frac{d_{mw}}{2} \quad (2)$$

$$W = (d_w - d)/2 \quad (3)$$

Where  $D_c$  is the worm crest diameter (mm),  $P_w$  is the worm pitch in mm,  $d_w$  is the worm strip diameter,  $d_{mw}$  is the worm mean diameter,  $r_{mw}$  is the worm mean radius. In order to avoid problem of slipping associated with belts driving system, a gear reducer, with speed ratio of 1:20 was considered. Hence, the speed of the shaft ( $v_s$ ) was determined to be 0.215 m/s using eqn. 4 ( $\pi=3.142$ ),

$$v_s = \frac{\pi d_{mn} N}{60} \quad (4)$$

Where  $d_{mn}$  is the worm mean diameter (mm) and  $N$  is the rotational speed (rpm).

### 2.2.2 Determination of Expeller Hourly Capacity

From the rated capacity, the hourly volumetric conveying capacity of the expeller ( $Q_{vol}$ ) is estimated to be 25 kg/h (0.24525 kN/h is 0.317 m<sup>3</sup>/h) using eqn. 5,

$$Q_{vol} = \frac{M_d}{36(v_s)} g \quad (5)$$

Where  $v_s$  represents the speed of the shaft,  $g$  is the acceleration due to gravity (m/s<sup>2</sup>).

### 2.2.3 Design of Hopper

The hopper is the housing where the material to be expelled is stored; It serves as the loading terminal of the system. The design of a hopper is based on the angle of repose principle which is the maximum angle of which a heap of any loose bulk material will stand within the sliding. Since hopper should have a shape that would facilitate ease- loading and complete gravity utilization through the discharge chute, a repose angle of 36.12° corresponding to friction coefficient of 0.73 for pulp was used [21]. To ensure principle of interchangeability of part, 50.8 mm and 250 mm diameter pipes were considered for the hopper design with the height of the top

cylindrical part same as the diameter, assuming the loading rate is 25 % of the total capacity, the volume of the hopper ( $V_h$ ), is estimated to be  $0.0132 \text{ m}^3/\text{loading}$ , with eqn.,

$$V_h = (\pi R_c^2 H_c) + \left[ \frac{\pi h_{fr}}{3} (R_c^2 + R_c r_{nf} + r_{nf}^2) \right] \quad (6)$$

### 2.2.4 Selection of Prime mover (electric motor)

After preliminary calculations, it was observed that for the required speed of 720 rpm to be attained from standard motor with rated speed of 1440 rpm, or speed ratio of 20, 8 belts would be required; but this would create excessive bending moment on the rotating shaft. Hence to eliminate this defect, a gearing system called gear reducer was hereby considered.

### 2.2.5 Outside Diameter of Flange

The outside diameter of flange ( $d_f$ ) and the thickness of protective flange ( $t_p$ ) ( $t_p = 0.5t_f$ ) were determined to be 107.95 mm and 5 mm, respectively, using eqns. 7 and 8, with  $d_1$  as the mean diameter,  $d_w$  as the diameter of hub of socket wrench, and  $t_f$  as the thickness of flange. Likewise, the diameter of hub of socket wrench ( $d_w$ ), the radius of bolt circle ( $r_b$ ), thickness of hub ( $t_h$ ), thickness of flange ( $t_h$ ) were determined to be 19 mm, 40.75 mm, 18 mm, 15 mm, respectively using eqns. 9 and 10, where  $d$  and  $d_b$  are shaft diameter and diameter of bolt circle, respectively.

The adopted type of coupling is flange coupling as the two shafts are axially designed

$$d_f = 2\left(\frac{d_1}{2} + d_w + t_2 + 2 \times \text{clearance}\right) \quad (7)$$

$$d_w = 1.85d_b + 8 \quad (8)$$

$$t_h = \frac{1}{2}(d_1 - d) \quad (9)$$

$$t_f = 0.5h + 6 \quad (10)$$

### 2.2.6 Diameter of Bolts

The bolts are designed individually to carry a shear of the load. The number of bolt ( $n$ ) was determined to be 4 using eqn. 11, where  $d$  is the shaft diameter and  $d_b$  is the bolt diameter. Radius of bolts ( $r_b$ ) obtained from the addition of radius of hub, clearance, and radius of hub of socket wrench was 60 mm. The pitch circle diameter of bolt ( $D_p = 3d$ ), bolt diameter, and shearing force in bolt ( $\mathcal{P}$ ) were determined to be 120 mm, 27 mm and 7.733 KN/mm<sup>2</sup>, respectively using eqns. 12 and 13, where  $d$  is the shaft diameter (mm),  $T_{max}$  is the maximum stress (N/mm<sup>2</sup>),  $\tau b$  is the bolt stress,  $T$  is the torque transmitted (N-m) and  $n$  is the no of bolts.

$$n = \frac{4d}{150} + 3 \tag{11}$$

$$T_{max} = \frac{\pi}{4} \times d_b^2 \times \tau_b \times n \times \frac{D}{2} \tag{12}$$

$$\mathcal{P} = \frac{T}{r_2 n} \tag{13}$$

### 2.2.7 Design of Shaft

The threaded shaft was designed for based on strength so as to withstand both bending and torsional moments due to the imposed loads. The diameter of the threaded shaft ( $d_{sh}$ ) was obtained with eqn. 14. The calculated shaft diameter is 55.3 mm, the nearest available diameter is 60 mm and was adopted.

$$d_{sh} = \sqrt[3]{\frac{16T_{max}}{\pi\tau}} \tag{14}$$

where:  $T_{max} = K_s T$ ; and  $T = \frac{P \times 60}{2\pi \times N}$

In eqn. 14,  $T_{max}$  represents the maximum torque transmitted (N-mm),  $K_s$  is the service factor,  $T$  is the torque transmitted (N-mm),  $\tau$  is the permissible shear stress in the shaft (MPa),  $P$  is the power transmitted (W),  $N$  is the rotational speed (rpm). For safety purpose, the shaft



dimensions were verified. With the shaft being subjected to torsion stress, the torque involved is determined using eqn. 15, and the permissible shear stress in the shaft ( $\tau$ ) was calculated to be 43.77 MPa. Since the induced shear stress 43.77 MPa is less than the working shear stress, 56 MPa, the design of the shaft is safe.

$$T_{max} = \frac{\pi}{16} \times d^3 \times \tau \quad (15)$$

### 2.2.8 Design of Coupling

In order to prevent twisting of shaft due to misalignment, a pair of flange type coupling is installed between the reducer and expeller shafts. With service factor ( $K_s$ ) for low speed haulage gear electric motor of 3.5, the torque ( $T$ ) and the maximum torque ( $T_{max}$ ) transmitted by the shaft are determined to be 530.448 N-m and 1856.568 N-m, respectively using eqns. 16 and 17, considering the power transmitted ( $P$ ) in W and the speed of rotation ( $N$ ) in rpm. However, the length of the hub is normally equal to the length of the key required. Width of key is obtained as 10 mm while the length of the key ( $L$ ) is obtained to be 60 mm ( $1.5d$ ), where  $d$  is the diameter of the shaft. Hence, to prevent the key from moving axially, a set screw is considered.

$$T = \frac{P \times 60}{2\pi \times N} \quad (16)$$

$$T_{max} = K_s T \quad (17)$$

After preliminary calculations, it was observed that 8 belts would be required to attain the required speed ( $72 \text{ rpm}$ ), but this would create excessive bending moment. Hence, a gearing system called gear reducer was hereby considered. The diameter of speed reducer flange ( $D_r$ ) was obtained to be 158.4 mm using eqns. 18 and 19 with the following parameters,

(i) Output speed of electric motor,  $N_e = 1440 \text{ rpm}$ .

(ii) Input speed of gear reducer,  $N_r = 1000rpm$

(iii) Rotational speed of expeller, =  $72rpm$

(iv) Electric motor flange diameter  $D_e = 110mm$

$$N_1D_1 = N_2D_2 = N_eD_e = N_rD_r \quad (18)$$

Velocity ratio between electric motor and reducer,

$$\frac{N_e}{N_r} = \frac{D_r}{D_e} \quad (19)$$

### 2.3 Construction Process

The fabrication was carried out at the central engineering workshop of the School of Engineering and Engineering Technology, Federal University of Technology, Akure, Ondo State, Nigeria. The orthographic view of the designed machine is illustrated in Figure 1. Figure 1a and b show the top and front views of the designed machine while the side view of the designed machine is illustrated in Figure 1c. Figure 2 shows the constructed improved groundnut oil expelling machine were fabricated from a standard-length angle iron of dimensions 1614 x 632 x 254 mm. Following the design specification, the angle iron was cut into appropriate sizes and welded together to serve as a support for the machine and the electric motor.

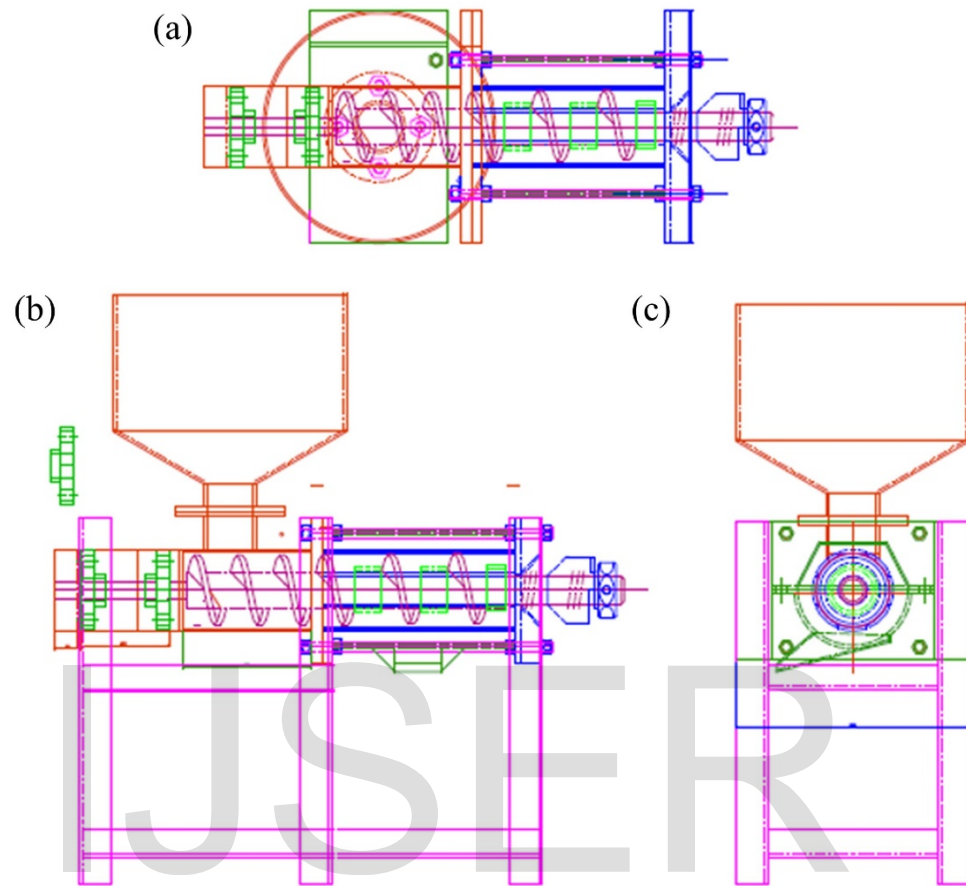

Figure 1. Orthographic view of the designed groundnut expelling machine, (a) top view, (b) front view, (c) side view.



Figure 2. The constructed improved groundnut oil expelling machine showing the different sides.

### 3. Results and discussions

#### 3.1 Performance Evaluation

Performance tests were carried out on the machine to evaluate its operational performance. While carrying out the test, machine was run on no-load for 5 minutes with a 3 phase, 72 rpm and 4.52 kW electric motor. After 5 minutes idle running, machine was loaded with 2.0 kg of dried groundnut, fed through its hopper, the die was adjusted to a clearance of 2 mm by mean of lock nut. Pressing time for 2.0 kg was noted (with a time recorder), weights of extracted oil and resulting cake were recorded, in succession, with a digital weighing balance (Model). After the first trial, another two trails were carried out and their resulting cake and oil were also recorded with the clearance of 2.0mm. The procedure was repeated for 3.0 mm and 4.0 mm clearance respectively. During the course of the experiment, the lock nut was the only part controlled and

die (cone) determines the pressing time, oil yield, feed rate and oil extraction rate for both trials.

The experimental results on the average of the pressing time, average weight of groundnut and average weight of cake obtained are as presented in Table 1.

Table 1. The comparison between the existing and improved groundnut oil expelling machine with respect with factors considered.

S/N	Pressing time (min)		Weight of Cake after milling (g)		Oil yield (g)		Feed rate (g/min)	
	Trial	Average	Trial	Average	Trial	Average	Trial	Average
1	7.5	7.7	2000	2000	1010	1006.7	990	993.3
2	7.7		2000		1008		992	
3	7.9		2000		1002		998	
1	7.0	6.8	2000	2000	1125	1145	875	861.7
2	6.8		2000		1130		870	
3	6.5		2000		1160		840	
1	6.3	5.6	2000	2000	1200	1223.7	800	776.4
2	6.1		2000		1225		775	
3	5.3		2000		1246		754	

### 3.2 Efficiency of the machine

Efficiency,  $\eta_m$  of the machine is obtained from the oil extraction efficiency E, which is given by

$$E = \frac{Y}{C_o} \times 100 \% \tag{20}$$

Where: Y is the oil yield in percentage,  $C_o$  is the oil content of nut (38% for groundnut seed-maximum). Therefore, oil yield Y is calculated from

$$Y = \frac{W_1 - W_2}{W_1} \times 100 \tag{21}$$

Where

$W_1$  is the weight of un-milled groundnut seed (25Kg)

$W_2$  is the weight of groundnut residue (after milling)

After milling, the groundnut residue was weighed and was recorded to be 15965 Kg

Therefore, oil yield, Y

$$\begin{aligned}
 &= \frac{W_1 - W_2}{W_1} \times 100 \\
 &= \frac{25000 - 15965}{25000} \times 100 \\
 &= 36.14\%
 \end{aligned}$$

Therefore, efficiency, E

$$\begin{aligned}
 &= \frac{0.3614}{0.38} \times 100 \\
 &= 95.2\%
 \end{aligned}$$

Table 2: Comparison between existing and improved groundnut oil expelling machine.

S/N	Factors Considered	Existing Expeller	Improved Expeller
1.	Size	Very big	Portable
2.	Speed at expelling medium	62 rpm	72 rpm
3.	Power Transmission Efficiency	Low output	High Output

#### 4. Conclusion

An improved groundnut oil expelling machine was developed and tested. Machine was portable enough for medium scale industries. The machine is easy to operate, repair and maintain. The expelling rate of the machine is a function of the resistance and constant pressure from the screw drives to move and compress the seed material. The use of 3hp electric motor has also

improved some ergonomics aspect of the design aspect of the design, such as noise cause fuel powered machines which could cause headaches and fatigue. The efficiency of the machine is 95.2 %. The cost of production of the machine is ₦160 000 Naira (\$445). The machine is highly recommended for medium scale and industries.

## References

- [1] Olawepo, O. S., Balogun, L. (2004). Performance evaluation of a palm kernel oil extracting machine. Proceedings of the 5th International Conference and 26th Annual General Meeting of the Nigerian Institution of Agricultural Engineers, 26, 308-311.
- [2] Alonge, A. F., Olaniyan, A. M., Oje, K., & Agbaje, C. O. (2004), Development of a screw press for village level groundnut oil extraction, Journal of Agricultural Engineering and Technology, 12,46-53.
- [3] Olaniyan A.M., Kamaldeen A. Yusuf, A. L., Afolayan K.O., Design, Development and Testing of a Screw Press Expeller for Palm Kernel and Soybean Oil Extraction, Agricultural Engineering International: The CIGR Journal of Scientific Research and Development, 8, 1-9 (2012).
- [4] Olaomi, J. (2008): Design and Construction of a Motorized Groundnut oil Expelling Machine” B.Eng Thesis, Department of Mechanical Engineering, University of Ilorin, Nigeria.
- [5] Gitau, A.N., Mboya, P., Njoroge, B.N.K., Mburu, M. (2013): Optimizing the Performance of a Manually Operated Groundnut (*Arachishypogaea*) Decorticator, Open Journal of Optimization, 2013, 2, 26-32.
- [6] Akinoso, R., Gbeka J.C.I. and Olayanju, T.M.A. (2006): Process Optimization of Oil Expression from Sesame Seed (*Sesamum indicum* Linn.), Federal Institute of Industrial Research Oshodi (FIIRO), Nigeria, pp1-7.

- [7] Oghome, P.I. (2012): Transesterification and Optimization of Groundnut Oil Using Magnetic Stirrer, Open Science Repository Engineering.
- [8] Bello, E.I., Fatimehin, D. (2015): Optimization of groundnut oil biodiesel production and characterization. Applied Science Reports, 9 (3), 172-180.
- [9] Olugbade T.O., Ojo O.T. Development and performance evaluation of an improved electric baking oven, Leonardo Electronic Journal of Practices and Technologies, 2018, 33: 189-206.
- [10] Olugbade T.O., Mohammed T.I., Ojo O.T. Static stress analysis and displacement of a tricycle rear shock absorber using finite element analysis, Leonardo Electronic Journal of Practices and Technologies, 2018, 33: 139-158.
- [11] Ojo O.T., Olugbade T.O. Development of an adjustable multi nut tighter or remover for car tyre, Leonardo Electronic Journal of Practices and Technologies, 2018, 32: 27-40.
- [12] Abioye T.E., Olugbade T.O., Ogedengbe T.I. Welding of dissimilar metals using gas metal arc and laser welding techniques: a review, Journal of Emerging Trends in Engineering and Applied Sciences, 2017, 8(6):225-228.
- [13] Akinnuli B.O, Olugbade T.O. Development and performance evaluation of piggery and water hyacinth waste digester for biogas production, International Journal of Engineering and Innovative Technology, 2014, 3(10): 271 – 276.
- [14] Akinnuli B.O, Olugbade T.O. Application of queue model for performance assessment of multi-channel multi-servers motor spirit filling station, International Journal of Engineering and Innovative Technology, 2014, 3(7): 74 – 81.
- [15] Akinola A.O., Olugbade T.O., Adamolekun T.M. Development of a 3-Seater chair-bed, International Journal of Engineering and Innovative Technology, 2014, 4(1): 177 – 181.



- [16] Mohammed T.I., Olugbade T.O., Odesanmi G.A. Development and performance evaluation of a pedal operated hydraulic jack, *Journal of Scientific Research and Reports*, 2015, 8(2): 1 – 8.
- [17] Ogedengbe T.I., Olugbade T.O., Olagunju O.R. Application of house of quality matrix to material selection for engineering designs, *British Journal of Applied Science and Technology*, 2015, 10(4): 1 – 11.
- [18] Mohammed T.I., Nwankwo I.C., Olugbade T.O. Determination of the effect of oil exploration on galvanized steel in Niger Delta, Nigeria, *Journal of Scientific Research and Reports*, 2016, 10(1): 1–9.
- [19] Ibeto C. N, Ofoefule A. U, Ezeugwu H. C. Fuel Quality Assessment of Biodiesel Produced from Groundnut Oil (*Arachis hypogea*) and its Blend with Petroleum diesel, *American Journal of Food Technology*, 2011, 6(9): 798-803.
- [20] Ajao K. R., Ajimotokan, H. A., Olaomi J. Development and performance evaluation of a groundnut oil expelling machine, *New York Science Journal*, 2009, 2(6), pp 07-08.
- [21] Fayose F.T. Development of multi-purpose sieving machine for wet agricultural products, *Agricultural Engineering International: the CIGR Ejournal*. Manuscript FP 08 006. Vol. X. December, 2008.